

General Install Instructions

Model 2720 (Square or Rectangular)

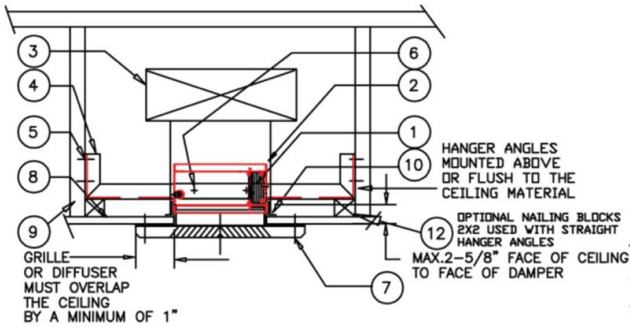

1. Ceiling Radiation Damper
2. Steel duct drop (less #3 plenum permitted)
3. Branch plenum, or plenum boot
4. Hanger angles (2) 1-1/2 x 1-1/2 x 16 gauge
5. #6 common nails or #8 x 1-1/4 screws
6. Mounting fasteners (bolts, screws, rivets)
7. Steel grille, diffuser, or drop ducting
8. Ceiling: Gypsum wallboard, acoustical tile, or acoustical panel (lay-in)
9. Joists, trusses, beams
10. Stabilizing angles (2) 1/2 x 1-1/2 x 16 GA x 3"
11. Mounting fasteners (bolts, screws, rivets)
12. Optional nailing blocks 2x2 used with straight hanger angles

Overview

These ceiling dampers are Classified by Underwriters Laboratories, Inc. as to heat barriers in the Fire Resistance Directory under the category of Ceiling Dampers (CABS). Refer to the Classification information in the back of the Fire Resistance Directory regarding the use of these dampers in the various floor-ceiling or roof-ceiling assemblies. Ceiling dampers and the associated components (surface mounted diffusers or grilles, ducts, etc.) which are to be constructed of steel, are installed in the ceiling to maintain the hourly ratings of the floor-ceiling assemblies which are rated 3 hours or less.

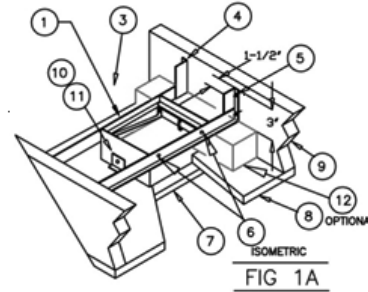

Installation Instructions:

1. Before installing the damper, Model 2720, open the curtain and hook the fusible link over the link catch on the opposite side of the curtain. Bend down the link catch to secure the link in position.
2. Measure the actual spacing between the joists or other structural members. Allowing for a 3.00" flange at each mounting point. Cut and bend the angles on both ends to 90 degrees, or the appropriate angle required. Mounting angles are fastened to joists or other structural members with a minimum of two fasteners for each mounting point using #6 common nails or #8 x 1-1/4" long screws.
3. Model 2720 is connected to the mounting angles with sheet metal screws, rivets, or bolts. Two connections on each angle as a minimum. Note: fastener positions must not interfere with the damper operation.
4. Model 2720 is connected to the stabilizing angles with sheet metal screws, rivets, or bolts. One connection on each angle as a minimum. The stabilizing angles are to be mounted with one face of the angle flush to the ceiling material. Note: fastener positions must not interfere with the damper operation.
5. The installation mounting position of the damper face must not exceed 2-5/8" from the face of the rated barrier.
6. Install the ceiling damper in the duct drop using 3/16 in. diameter by 1/2 inch long steel bolts. No. 8 by 1/2 inch steel sheet metal screws or 3/16 inch diameter steel rivets at 6 inches O.C. and a minimum of (3) places. For flexible ducting; connect with draw clamps, #16 SWG wire, or cable ties as per SMACMA Standards requirements.
7. The clearance between each side of the ceiling damper and the duct drop shall be 1/8 inch maximum.
8. The maximum size of Model 2720 is 14" W x 14" H.
9. Steel/Aluminum grille or diffuser to be attached to the duct drop or ceiling dampers using No. 8 by 1-1/2 inch long sheet metal screws.

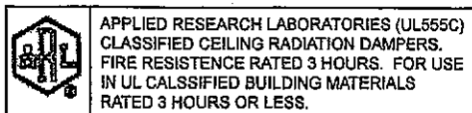

All INSTALLATIONS ARE SUBJECT TO LOCAL AUTHORITY APPROVAL PRIOR TO ORDERING DAMPERS AND DAMPER INSTALLATION